

PENNSAFE BUILDING INSPECTION SERVICES LLC

175 Beaver Drive, PO Box 486 – DuBois, PA. 15801

Phone: 814-375-1111

Fax: 814-375-1117

Accessible Ramps and Landings

This tip sheet reflects code requirements of the 2021 International Building Code (IBC) and ICC A117.1-2017.

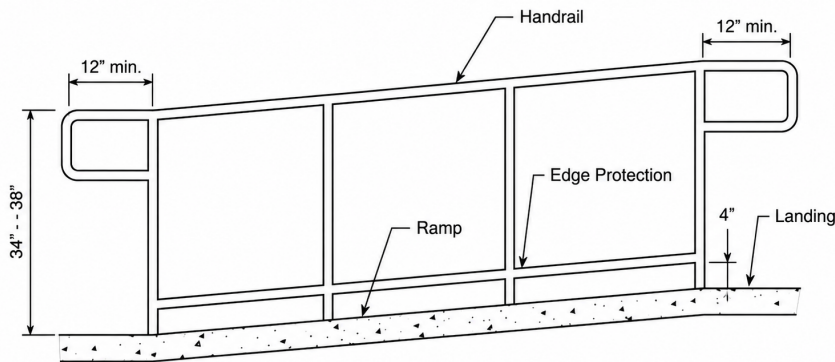

Typical Ramp Features

Ramps

Slope: The maximum ramp slope shall be 1 unit rise to 12 units run. (IBC 1012.2, ICC 405.2)

Rise: The maximum rise for any ramp run is 30 inches. (IBC 1012.4, ICC 405.6)

Width: Ramps shall not be less than the required agrees width for corridors by IBC 1020.3; in no case shall the ramp width be less than 36 inches for interior ramps or 48 inches for exterior ramps, measures between handrails or other projects. (IBC 1012.5.1, 1101.2.2, ICC 403.5.1)

Surface: Ramp surfaces shall be stable, firm and slip resistant. (ICC 405.2, ICC 302)

Drainage: Exposed exterior ramps and their approaches shall be constructed to prevent the accumulation of water on walking surfaces. (ICC 405.10)

Cross Slope: Maximum ramp cross slopes shall not be steeper than 1 unit rise to 48 units run. (IBC 1012.3, ICC 405.3)

Headroom: Headroom shall not be less than 80 inches (ICC 307.2)

Handrails

Rise: Ramps with a rise greater than 6 inches require handrails. (ICC 405.8)

Height: Handrails must be a maximum uniform height between 34 inches minimum and 38 inches measured above the finished surface. (IBC 1014.2.1; ICC 505.4)

Extension: Handrails must extend at least 12 inches beyond the top and bottom of any ramp run. (ICC 505.10.1)

Continuity: Handrails must be continuous except at points of access along the ramp. Handrail grasping surfaces shall not be obstructed. (IBC 1014.4; ICC 505.3)

Guards

Landings or Ramps: Provide guards for portions of landings or ramps that are more than 30 inches measures vertically to the floor or grade below at any point within 36 inches horizontally to the edge of the open side. (IBC 1015.2)

Height: Guards must be a minimum of 42 inches in height measured vertically from the surface of the ramp, except within the individual dwelling units in Group R2 or R3, guards may be 36 inches in height above the adjacent walking surface. (IBC 1015.3)

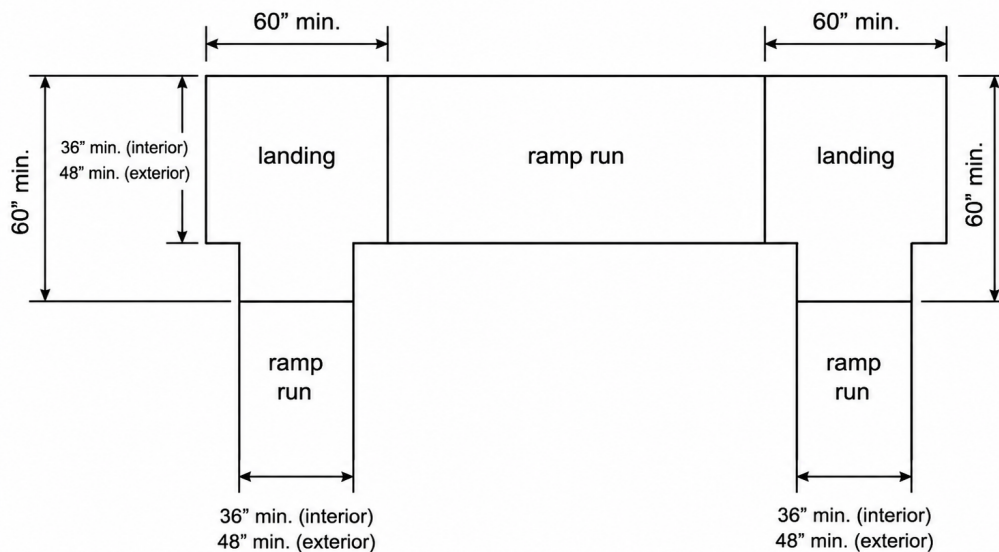

Ramp Layout Dimensions

Landings

Surface: Ramp surfaces shall be stable, firm and slip resistant materials securely attached.

Drainage: Exposed exterior ramps and their approaches shall be constructed to prevent the accumulation of water on walking surfaces. (IBC 1012.7.2, ICC 405.10)

Intermediate Landing: Ramps shall have landings at the top and bottom, points of turning, entrance, exits, and doors and at least one intermediate landing for each 30 inches of rise with a minimum dimension of 60 inches in direction of the ramp run. (ICC 405.7.3)

Change of Direction: Ramps that change direction at landings shall have per ICC 405.7.4:

Landings sized to provide a 60 inches by 60 inches space for changing direction, or

A T-shaped intersection 60 inches long by 36 inches wide (interior) or 48 inches (exterior).

Width: The minimum width of the landing shall be the width of the widest ramp adjoining the landing. (IBC 1012.6.2, ICC 405.7.2)

Cross Slope: Landings shall not have a cross slope steeper than 1 unit rise to 48 units run. (IBC 1012.6.1, ICC 405.7.1)

Doors: Maneuvering clearances for doors may overlap the landing area where doorways are adjacent to the ramp. (ICC 405.7.5)

Edge Protection

Where Required: Edge protection is required on each side of ramp runs and at each side of ramp landings. (IBC 1012.10, ICC 405.9) Exceptions:

Edge protection is not required on ramps that are not required to have handrails, provided they have flared sides complying with ICC 406.3

Edge protection is not required on side of ramp serving an adjacent ramp run or stairway

Edge protection is not required on sides of ramp landings having a vertical drop-off of not more than 1/2 inches with 10 inches horizontally of the required landing area

Edge protection shall not be required on the side of the ramp aisles where the ramps provide access to the adjacent seats and aisle access ways.

Extended Floor Surface (Option 1): Extend the floor surface of the ramp run or ramp landing a minimum of 12 inches beyond the inside face of a railing complying with IBC 1014. (See the figure below). (IBC 1012,10.2, ICC 405.9.1)

Curb (Option 2): Create a curb that is a minimum height of 4 inches (see figure below). (IBC 1012.10.1, ICC 405.9.91; ICC 405.9.2.1)

Wall or Barrier (Option 3): Construct a wall or barrier to prevent the passage of a 4-inch diameter sphere where any portion of the sphere is within 4 inches of the floor or ground surface (see figure below). (IBC 1012.10.1, ICC 405.9.2.2)

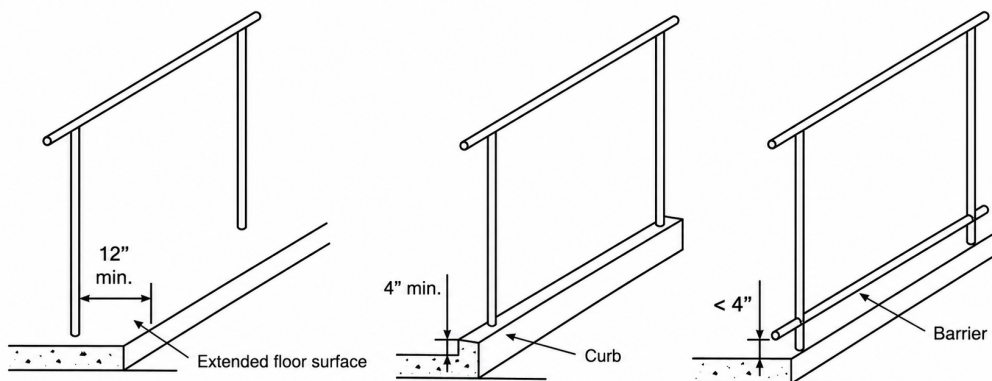

Edge Protection Options